



PFC Device Corporation

PSM7N50CT

7.6A 500V Single N-Channel Power MOSFET

Major ratings and characteristics

Characteristics	Values	Units
$V_{DS@T_J \text{ max}}$	500	V
$R_{DS(ON), V_{GS}=10V}$	0.5	Ω
I_D	7.6	A

General Description

PFC MLSJ (Multi-Layer Super Junction) MOSFET technology is the ideal choice for the PFC and PWM application. PFC device provides practical advantages of higher pressure-resistance, lower on-resistance to achieve the ideal balance between the switching speed and on-resistance.

Typical Applications

PFC stages, hard switching PWM stages and resonant switching stages for PC, Adapter, LCD & PDP TV, Lighting, Server, Telecom and UPS.

Please note: For MOSFET paralleling the use of ferrite beads on the gate or separate totem poles is generally recommended.

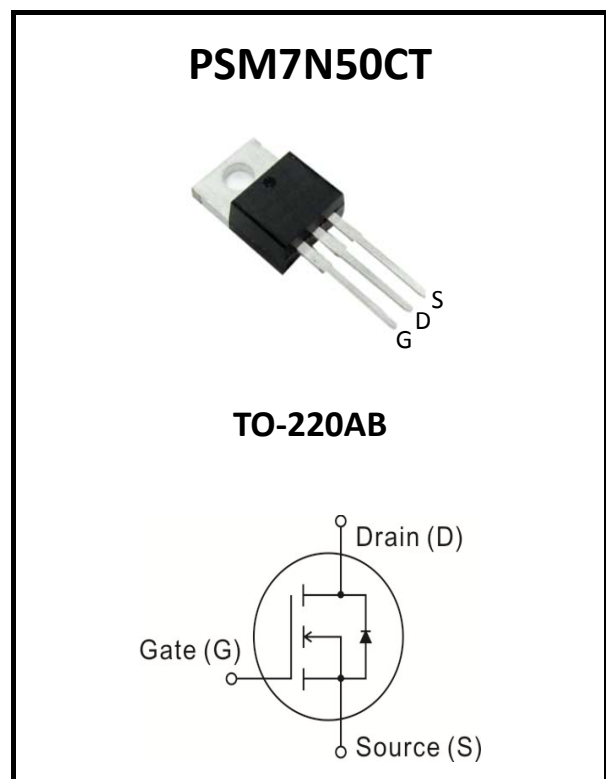

Features

- Advanced High Voltage Technology
- Low On-Resistance
- Low Gate Threshold Voltage
- Low Input Capacitance
- Extreme dv/dt rated
- Lead Free Finish, RoHS Compliant

1. Characteristics

Maximum Ratings Characteristics

($T_A = 25^{\circ}\text{C}$ unless otherwise specified)

Symbol	Parameter	Rating	Units
V_{DSS}	Drain-Source Voltage	500	V
I_D	Drain Current – Continuous ($T_C=25^{\circ}\text{C}$)	7.6	A
	Drain Current – Continuous ($T_C=100^{\circ}\text{C}$)	4.6	A
$I_{Dpulsed}$	Pulsed Drain Current tp limited by T_{Jmax} (Note 1)	22.8	A
E_{AS}	Single Pulse Avalanche Energy(Noted 2)	230	mJ
I_{AR}	Avalanche Current, repetitive t_{AR} limited by T_{Jmax}	7.6	A
V_{GS}	Gate-Source Voltage Static	± 20	V
V_{GS}	Gate-Source Voltage AC ($f > 1\text{Hz}$)	± 30	V
P_{tot}	Power Dissipation	83	W
T_{STG}	Storage Temperature Range	-55 to 150	$^{\circ}\text{C}$
T_J	Operating Junction Temperature Range	-55 to 150	$^{\circ}\text{C}$
dv/dt	Peak Diode Recovery dv/dt (Note 3)	15	V/nS

Thermal Characteristics

Symbol	Parameter	Typ.	Max.	Unit
$R_{\theta JA}$	Thermal Resistance Junction to ambient	---	62	$^{\circ}\text{C/W}$
$R_{\theta JC}$	Thermal Resistance Junction to case (Drain)	---	1.5	$^{\circ}\text{C/W}$



Electrical Characteristics ($T_J = 25^\circ\text{C}$ unless otherwise specified)

Off Characteristics

Symbol	Parameter	Conditions	Min.	Typ.	Max.	Unit
BV_{DSS}	Drain-Source Breakdown Voltage	$V_{GS}=0V, I_D=250\mu A$	500	---	---	V
I_{DSS}	Drain-Source Leakage Current	$V_{DS}=500V, V_{GS}=0V, T_J=25^\circ\text{C}$	---	0.5	1	μA
		$V_{DS}=500V, V_{GS}=0V, T_J=150^\circ\text{C}$	---	---	100	μA
I_{GSS}	Gate-Source Leakage Current	$V_{GS}=\pm 20V, V_{DS}=0V$	---	---	± 100	nA

On Characteristics

$R_{DS(on)}$	Static Drain-Source On-Resistance	$V_{GS}=10V, I_D=4.6A, T_J=25^\circ\text{C}$	---	0.45	0.5	Ω
		$V_{GS}=10V, I_D=4.6A, T_J=150^\circ\text{C}$	---	1.4	---	Ω
$V_{GS(th)}$	Gate-Source Threshold Voltage	$V_{GS}=V_{DS}, I_D=350\mu A$	2.1	3.0	3.9	V
R_G	Gate input resistance	f=1MHz, open Drain	---	0.87	---	Ω

Dynamic and switching Characteristics

Q_{gs}	Gate-Source Charge	$V_{DD}=400V, I_D=7.6A, V_{GS}=0$ to 10V	---	5	---	nC	
Q_{gd}	Gate-Drain Charge		---	13	---		
Q_g	Gate charge total		---	26	---		
g_{fs}	Transconductance	$V_{DS} \geq 2 \cdot I_D \cdot R_{DS(on)max}, I_D=4.6A$	---	7	---	S	
C_{iss}	Input Capacitance	$V_{GS}=0V, V_{DS}=25V,$	f=1MHz	---	780	pF	
C_{oss}	Output Capacitance	$V_{GS}=0V, V_{DS}=100V,$		---	42		---
C_{rss}	Reverse Transfer Capacitance	$V_{GS}=0V, V_{DS}=100V,$		---	26		---

Drain-Source Diode Characteristics and Maximum Ratings

V_{SD}	Inverse diode forward voltage	$I_S=7.6A, V_{GS}=0V$	---	1	1.2	V
t_{rr}	Reverse Recovery Time	$V_R=400V, I_F=7A, di_F/dt=100A/\mu S$	---	290	---	ns
Q_{rr}	Reverse Recovery Charge		---	3	---	μC
I_{rrm}	Peak reverse recovery current		---	20	---	A

Note :

1. Repetitive Rating: Pulsed width limited by maximum junction temperature.
2. $V_{DD}=50V, I_D=3.5A, \text{Starting } T_J=25^\circ\text{C}.$
3. $I_{SD} \leq I_D, di/dt \leq 400A/\mu s, T_J < T_{J,max}$



2. Characteristics Curves

Ratings and Characteristics Curves

($T_A = 25^\circ\text{C}$ unless otherwise specified)

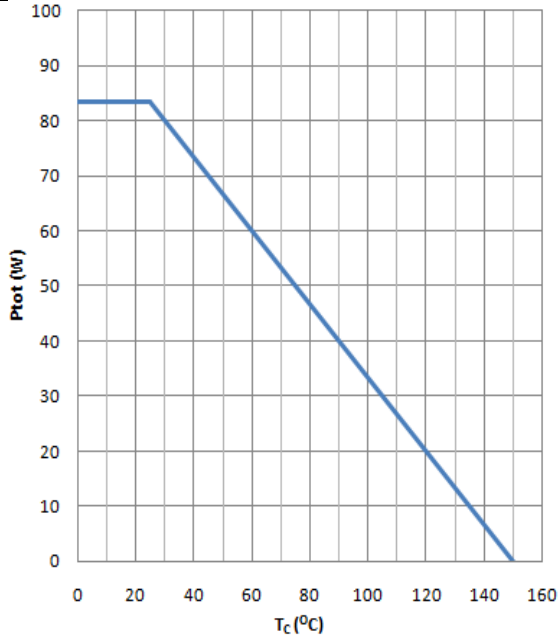

Figure 1: Power Dissipation
 $P_{tot} = f(T_c)$

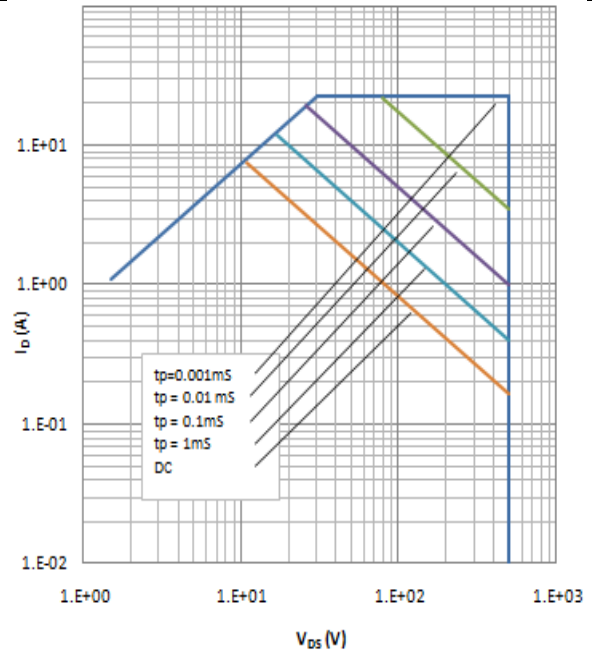

Figure 2: Safe operating area
 $I_D = f(V_{DS})$
 parameter : $D = 0, T_c = 25^\circ\text{C}$

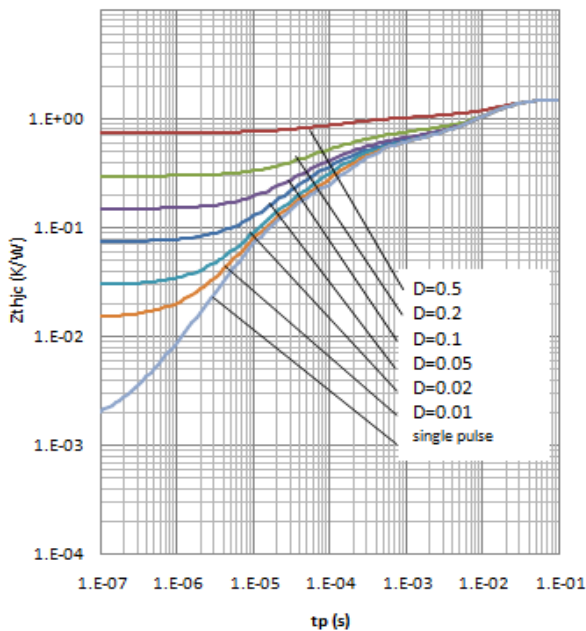

Figure 3: Transient thermal impedance
 $Z_{thjc} = f(tp)$
 parameter : $D = tp / T$

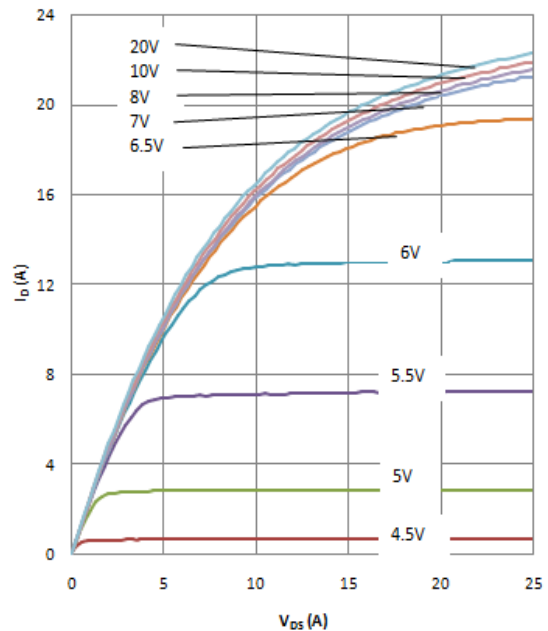

Figure 4: Typ. Output Characteristics
 $I_D = f(V_{DS}) ; T_j = 25^\circ\text{C}$
 parameter : $tp = 20\mu\text{s}, V_{GS}$



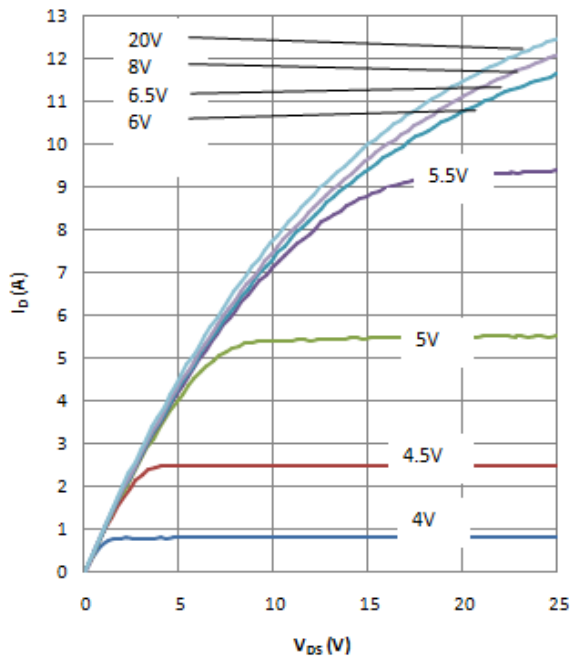

Figure 5:Typ. Output Characteristics
 $I_D = f(V_{DS})$; $T_j = 150^\circ\text{C}$
 parameter : $t_p = 20\mu\text{s}$, V_{GS}

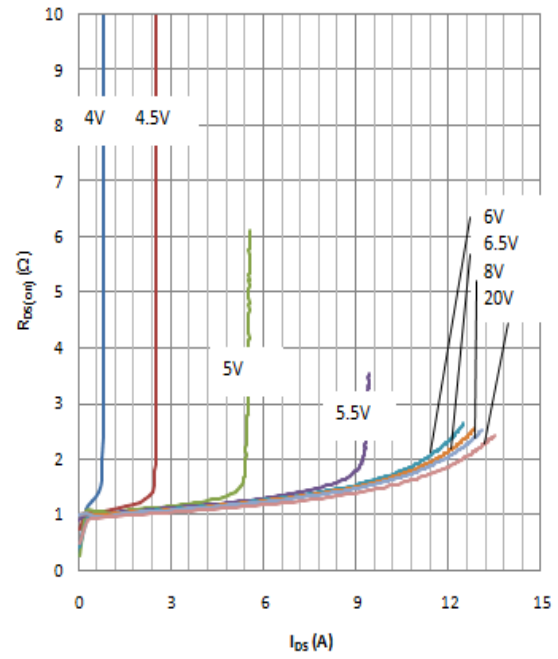

Figure 6: Typ. Drain Source On-Resistance
 $R_{DS(on)} = f(I_D)$
 parameter : $t_p = 20\mu\text{s}$, $T_j = 150^\circ\text{C}$, V_{GS}

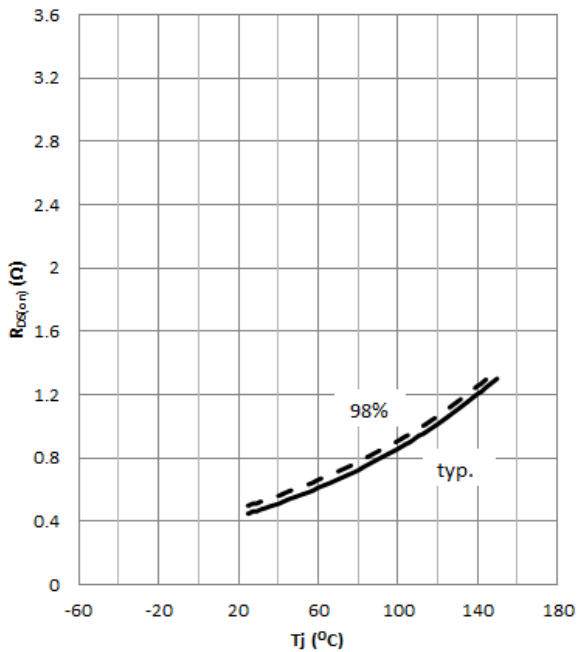

Figure 7: Drain-Source On-state Resistance
 $R_{DS(on)} = f(T_j)$
 parameter : $I_D = 4.6\text{A}$, $V_{GS} = 10\text{V}$

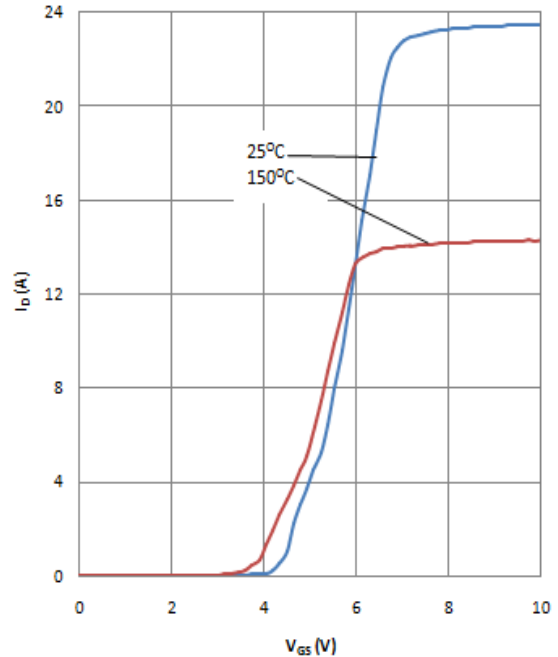

Figure 8: Typ. Transfer Characteristics
 $I_D = f(V_{GS})$; $V_{DS} \geq 2 \times I_D \times R_{DS(on) \text{ max}}$
 parameter : $t_p = 20 \mu\text{s}$



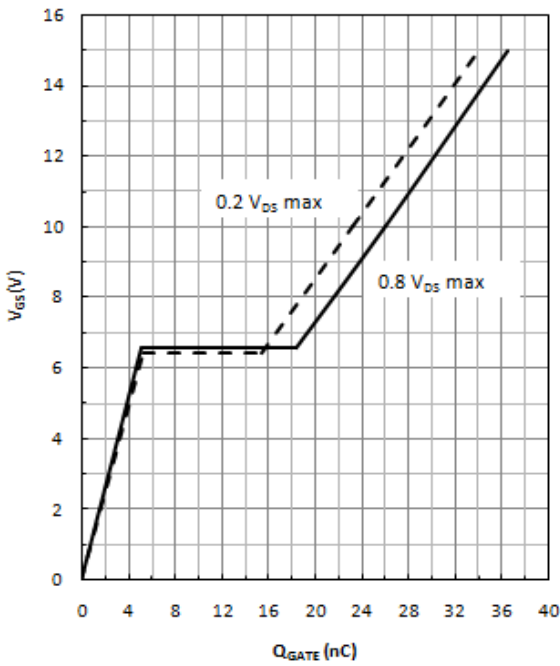

Fig 9: Typ. Gate Charge
 $V_{GS} = f(Q_{GATE})$
 parameter : $I_b = 7.6A$ pulsed

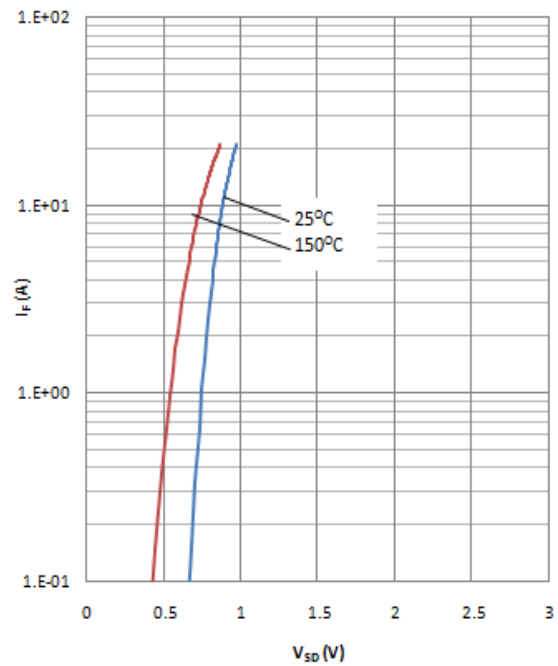

Fig 10: Forward characteristics of body diode
 $I_F = f(V_{SD})$
 parameter : T_j , $t_p = 20\mu s$

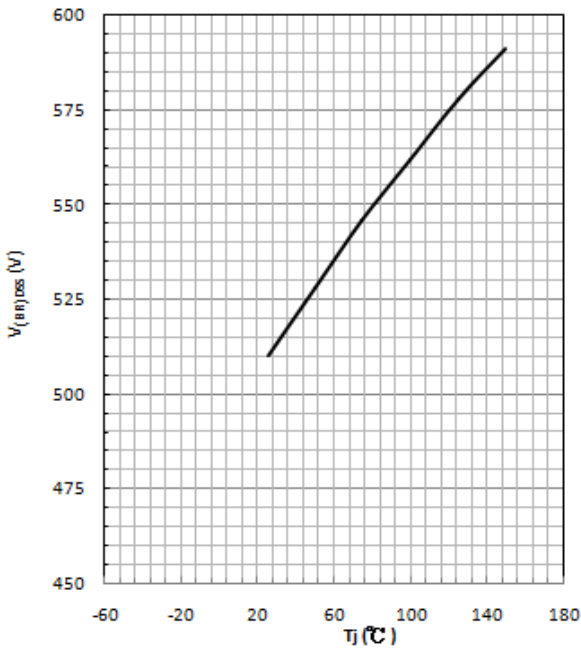

Fig 11: Drain-source breakdown voltage
 $V_{(BR)DSS} = f(T_j)$

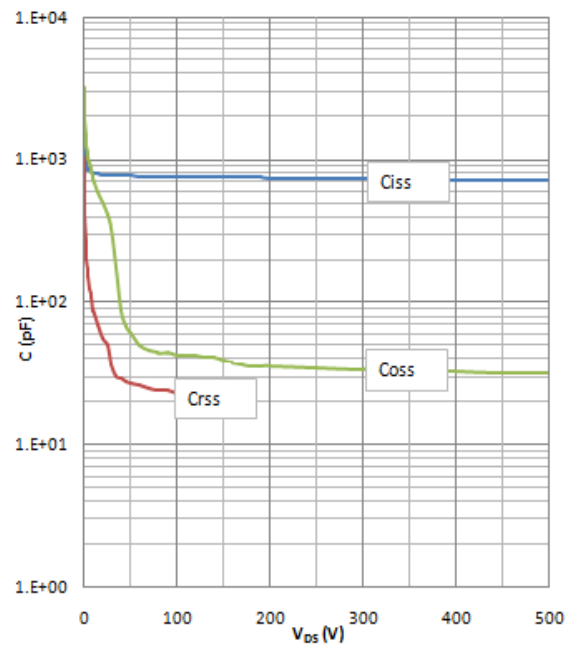

Fig 12: Typ. Capacitances
 $C = f(V_{DS})$
 parameter : $V_{GS} = 0V$, $f = 1MHz$



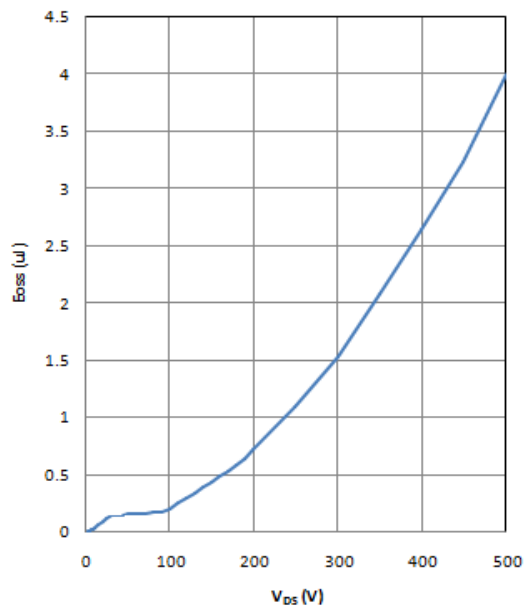

Fig 13: Typ. Coss stored energy

$E_{oss} = f(V_{Ds})$



3. Test Circuits and Waveforms

Test Circuits and Waveforms

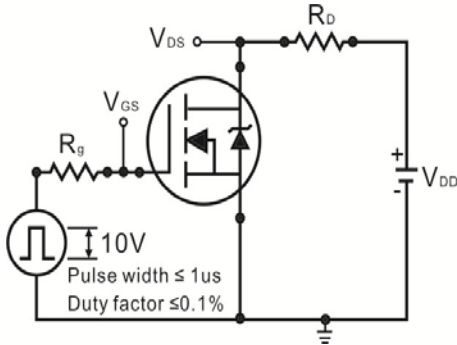

Figure 1: Switching times test circuit

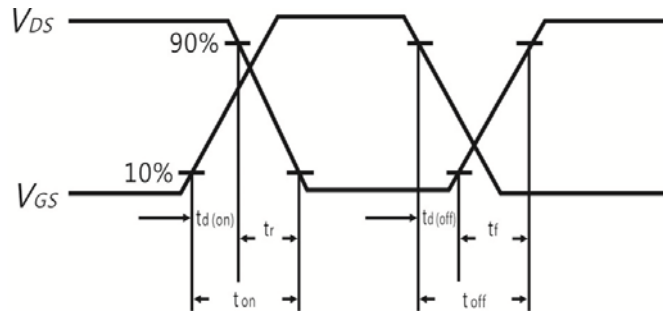

Figure 2: Switching time waveform

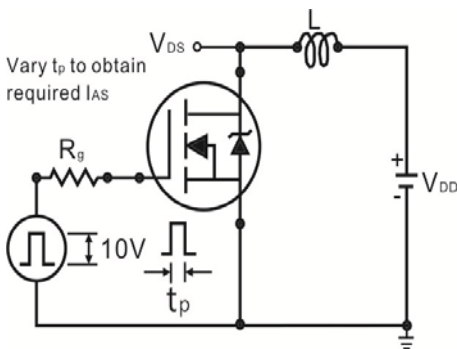

Figure 3: Unclamped test circuit

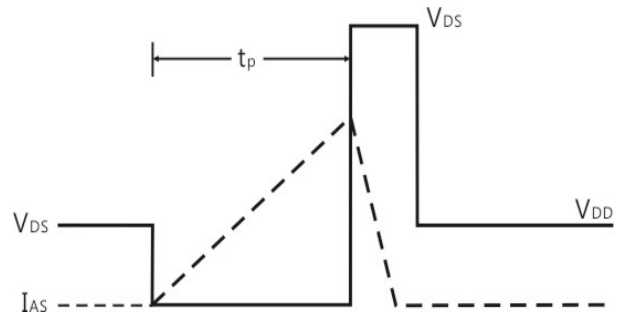

Figure 4: Unclamped test waveform

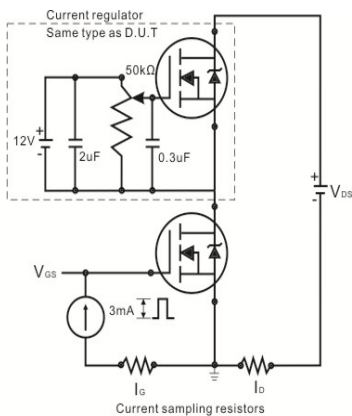

Figure 5: Gate charge test circuit

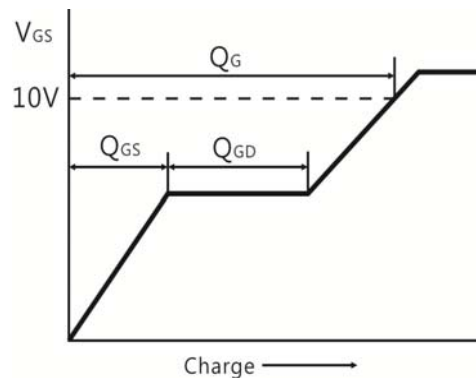
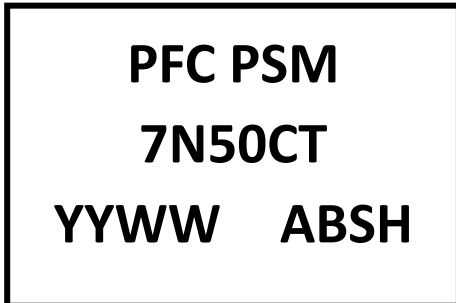

Figure 6: Basic gate charge waveform



4. Marking information

Top Marking Rule



PSM7N50CT = Product Type Marking Code

YY = Last two digits of year

WW = Week code

ABS = Assembly code

H = Halogen Free (N/A = common molding compound)

5. Package information

Package Outline Dimensions millimeters

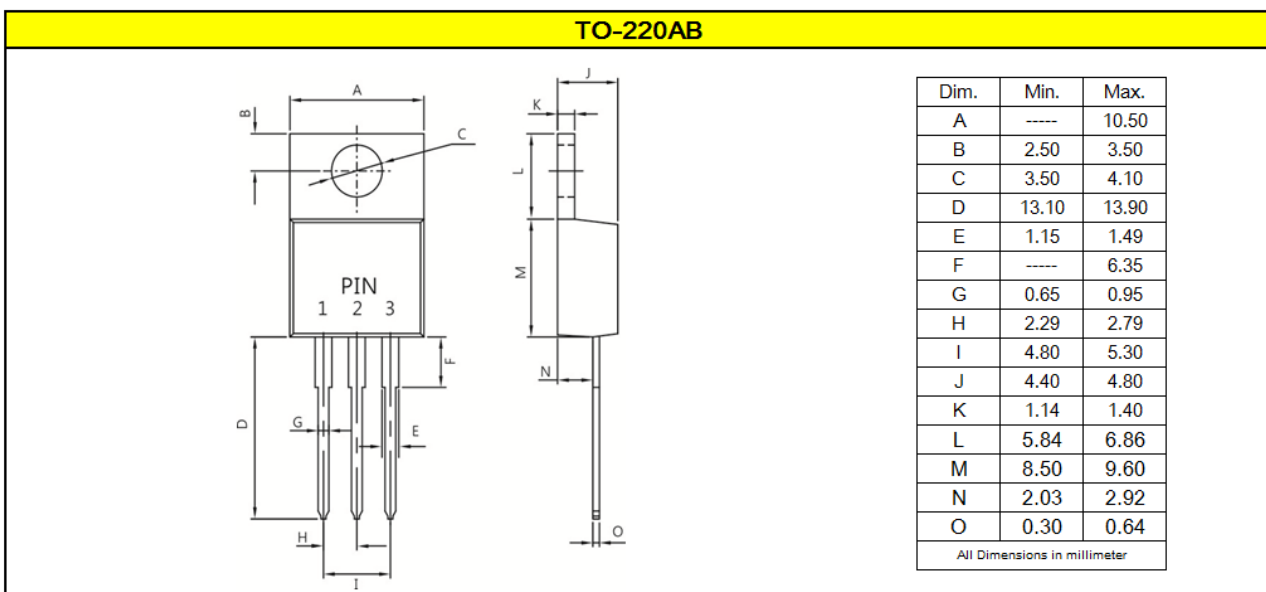

6. Ordering information

Part Number	Package	Delivery mode
PSM7N50CT	TO-220AB	50 pieces / tube

Note: For Halogen Free molding compound, add "H" suffix to part number above.

Mechanical

- Molder Plastic: UL Flammability Classification Rating 94V-0
- Device Weight : 0.07 ounces (1.96grams) – TO-220AB
- Mounting Torque : Recommended 10 in-lbs maximum

PFC Device Corp reserves the right to make changes without further notice to any products herein. PFC Device Corp makes no warranty, representation or guarantee regarding the suitability of its products for any particular purpose, nor does PFC Device Corp assume any liability arising out of the application or use of any product or circuit, and specifically disclaims any and all liability, including without limitation special, consequential or incidental damages. "Typical" parameters which may be provided in PFC Device Corp data sheets and/or specifications can and do vary in different applications and actual performance may vary over time. All operating parameters, including "Typical" must be validated for each customer application by customer's technical experts. PFC Device Corp does not convey any license under its patent rights nor the rights of others. PFC Device Corp products are not designed, intended, or authorized for use as components in systems intended for surgical implant into the body, or other applications intended to support or sustain life, or for any other application in which the failure of the PFC Device Corp product could create a situation where personal injury or death may occur. Should Buyer purchase or use PFC Device Corp products for any such unintended or unauthorized application, Buyer shall indemnify and hold PFC Device Corp and its officers, employees, subsidiaries, affiliates, and distributors harmless against all claims, costs, damages, and expenses, and reasonable attorney fees arising out of, directly or indirectly, any claim of personal injury or death associated with such unintended or unauthorized use, even if such claim alleges that PFC Device Corp was negligent regarding the design or manufacture of the part.

